



深圳飞特模型有限公司

SHENZHEN FEETECH RC MODEL CO.,LTD.

产品规格书

PRODUCT SPECIFICATION

客 户 (CUSTOMER) :
型 号 (MODEL) : FT90M-C012
名 称 (PRODUCT NAME): 6V 2.3kg.cm数码280度塑料壳双轴铜齿铁芯舵机
版 本 (EDITION) : A/0

在您下单采购本产品之前, 请阅读本规格书并在下列确认栏内签字回传。

Sign back before you place an order to purchase this product,
please read this specification and in the following admit column.

飞特确认/ FEETECH APPROVED

编写 EDIT	审核 CHECKED	确认 APPROVED
李永传	巫耿炎	冯潭新

客户确认/CUSTOMER APPROVED

审阅 REVIEW	审核 CHECKED	确认 APPROVED

地址: 广东省深圳市龙岗区横岗镇六约埔厦路60号2楼
ADD: Floor 2, No 60, PuXia Road, LiuYueHengGang Town, Long Gang District,
ShenZhen, 518173, China
电话/Tel: 0755-89335266 网址/Website: www.feetech.cn

		深圳飞特模型有限公司 SHENZHEN FEETECH RC MODEL CO., LTD.		版本EDITION: A/0
型号/MODEL: FT90M-C012		产品规格书 PRODUCT SPECIFICATION		日期/Date: 2022-4-11
页 码 Page: 3/7				
1. 使用环境条件 Apply Environmental Condition:				
No.	项目 (Item)		规格 (Specification)	
1-1	保存温度Storage Temperature Range		-30℃~80℃	
1-2	运行温度Operating Temperature Range		-20℃~60℃	
2. 测试环境 Standard Test Environment:				
No.	项目 (Item)		规格 (Specification)	
2-1	温度 Temperature Range		25℃ ±5℃	
2-2	湿度 Humidity Range		65%±10%	
3. 安全特性与认证 Secure Performance and Certificate				
No.	项目/Item	认证Certificate	备注 (remarks)	
3-1	ASTM F963	No	美国玩具检测标准	
3-2	EN71	No	欧盟市场玩具类产品的规范标准	
3-3	FCC	No	对电子、电器中的电磁干扰，管理和控制无线电频率范围，保护电信网络、电器产品的正常工作。	
3-4	ROHS	Yes	电子，电器设备中对人体有害物质的含量。	
3-5	REACH	NO	欧盟法规《化学品的注册、评估、授权和限制》	
4. 外观检查 Appearance Inspection:				
No.	项目 (Item)		规格 (Specification)	
4-1	外观尺寸OutlineDrawing		尺寸见附件(第12项) See the appendix	
4-2	外观Appearance		无损坏，不允许影响功能 No damage and mustn't affect functions.	
5. 电气特性 Electrical Specification				
No.	项目 (Item)	规格 (Specification)	规格 (Specification)	备注Remark
5-1	工作电压 Operating Voltage	4.8V	6V	
5-2	空载速度 No Load Speed	0.125sec/60° (80RPM)	0.1sec/60° (100RPM)	
5-3	空载电流 Running Current (no load)	120mA	150mA	
5-4	堵转扭力 Stall Torque (at locked)	1.89kg.cm	2.3kg.cm	
		26.3oz.in	31.99oz.in	
5-5	堵转电流 Stall Current (at locked)	800mA	1000mA	
5-6	静态电流 Idle Current (at stopped)	5mA	6mA	
5-7	工作电压 Input Voltage	3V-8.4V		
5-8	额定负载 Rated Torgue	0.6kg.cm	0.7kg.cm	
5-9	额定电流 Rated Current	250mA	350mA	
5-10	Kt常数	2.3kg.cm/A		

	<p style="text-align: center;">深圳飞特模型有限公司 SHENZHEN FEETECH RC MODEL CO., LTD.</p>	<p style="text-align: center;">版本EDITION: A/0</p>
<p style="text-align: center;">型号/MODEL: FT90M-C012</p>	<p style="text-align: center;">产品规格书 PRODUCT SPECIFICATION</p>	<p style="text-align: center;">日期/Date: 2022-4-11</p>
页 码 Page: 4/7		

6 机械规格 Mechanical Specification:

No.	项目 (Item)	规格 (Specification)	备注 (remarks)				
6-1	外观尺寸 Size	23.2X12.1X25.25mm	见图纸See drawings				
6-2	机构极限角度 Limit Angle	No limit					
6-3	外壳材质 Case material	PC plastic					
6-4	齿轮材质 Gear material	Metal Gear					
6-5	轴承类型 Bearing type	No					
6-6	角度传感器 Angle Sansor	类型Type	Carbon-Film Potentiometer				
		角度 Angle	330°				
		寿命 Life	100000Cycles Min				
6-7	连接器和电缆 Connector and Cable	类型 Type	JR				
		Material材 质	PVC				
		线长度 Length	25CM				
		引脚定义 Pin Definition	<table border="1" style="display: inline-table; border-collapse: collapse;"> <tr> <td>1</td> <td>Signal</td> </tr> <tr> <td>2</td> <td>Vcc</td> </tr> <tr> <td>3</td> <td>GND</td> </tr> </table>	1	Signal	2	Vcc
1	Signal						
2	Vcc						
3	GND						
							
6-8	重量The Weight	13.5± 1g					
6-9	出力轴 Horn Type	20T/3.95mm					
6-10	减速比Gear Ratio	1/416					
6-11	齿轮虚位Back Lash	≦2.0°					
6-12	摇臂虚位 The rocker phantom	0°					
6-13	出力轴螺丝 The rocker screw	M2.0X4					
6-14	马达Motor	Core Motor					

7 控制特性Control Specification:

No.	项目 (Item)	规格 (Specification)	备注 (remarks)
7-1	控制信号 Command Signal	Pulse width modification	
7-2	控制系统类型 Control System Type	Digital comparator	
7-3	操作角度 Operating Travel	280° (at 1000→2000 μ sec)	
7-4	两边角度差 Left&Right Travelling Angledeviation	≦ 5°	
7-5	回中差 Centering Deviation	≦2°	
7-6	中立位置 Neutral Position	1500 μ sec	
7-7	死区宽度 Dead Band Width	≦4 μ sec	
7-8	旋转方向 Rotating Direction	逆时针 Counterclockwise (在1500 →2000 μ sec)	
7-9	脉波宽度范围 Pulse Width Range	1000→2000 μ sec	
7-10	电子保护 Electronic Protection	堵转3秒/Stall 3sec	舵机堵转后, 输出扭矩超过 过载扭矩并持续超过3S 后自动输出保护扭矩, 可 修改过载扭矩, 保护时间 及保护扭矩。



深圳飞特模型有限公司
SHENZHEN FEETECH RC MODEL CO., LTD.

版本EDITION:
A/0

型号/MODEL:
FT90M-C012

产品规格书
PRODUCT SPECIFICATION

日期/Date:
2022-4-11

页 码 Page: 5/7

8 可靠性测试 Reliability Testing

No.	项目 (Item)	规格 (Specification)	备注 (remarks)
8-1	负载寿命测试Life test	>50000次	正转60度0.25S, 停0.5S, 反转60度0.25S, 停0.5S为一次, 持续循环工作, 负载1/5堵转扭力/速度为1/2, 测试电压6V。
8-2	马达噪音The motor noises	45±5dB	环境噪音40-45 dB 距离噪音仪30cm处测试
8-3	舵机噪音Steering gear noises	65±5dB	环境噪音40-45 dB 距离噪音仪30cm处测试/测试电压6V-1/3空载速度
8-4	防水性能Waterproof performance	No	

9 外观尺寸 Outside Dimension(单位Unit: mm)

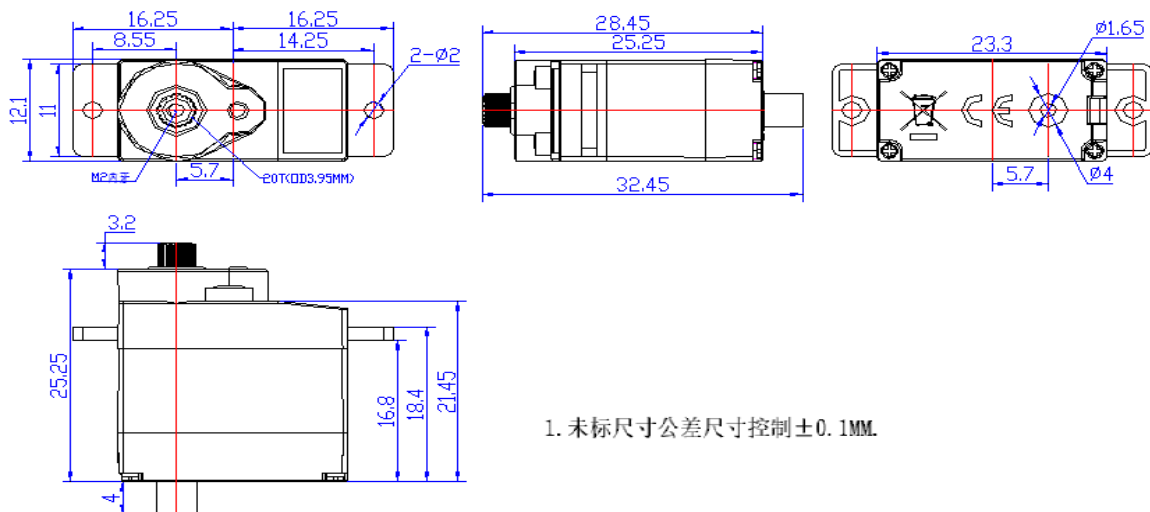

1. 未标尺寸公差尺寸控制±0.1MM.



深圳飞特模型有限公司
SHENZHEN FEETECH RC MODEL CO., LTD.

版本EDITION:
A/0

型号/MODEL:
FT90M-C012

产品规格书
PRODUCT SPECIFICATION

日期/Date:
2022-4-11

页 码 Page: 6/7

10 配件 Accessories

No Accessories



深圳飞特模型有限公司
SHENZHEN FEETECH RC MODEL CO., LTD.

版本EDITION:
A/0

型号/MODEL:
FT90M-C012

产品规格书
PRODUCT SPECIFICATION

日期/Date:
2022-4-11

页 码 Page: 7/7

11 接口定义 Interface Definition

控制信号参数 (Control signal parameter)

信号周期 Signal Period	20ms	
脉冲宽度 Pulse Width	1000us-2000us	
信号高电平电压 Signal high Voltage	2V-5V	
信号低电平电压 Signal Low Voltage	0.0V-0.45V	

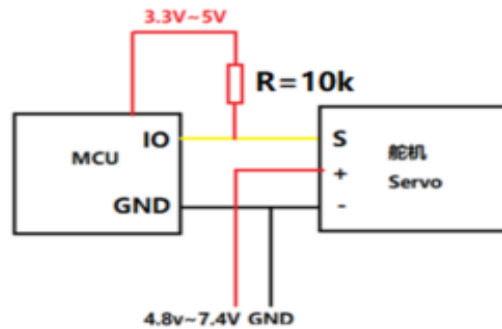

12 包装出货简图 The Packaging Detail

