

产品规格书

Specification of Product

V1.0 Page 1/3

产品名称: 12V 190kg. cm数码180度磁编码全铝壳钢齿轮无刷舵机

产品型号 Model No. FT-150BL-C002

1. 使用环境条件 Apply Environmental Condition

No.	Item	Specification
1-1	存储温度 Storage Temperature Range	-40℃~80℃
1-2	运行温度 Operating Temperature Range	-20℃~60℃

2. 测试环境 Standard Test Environment

No.	Item	Specification
2-1	温度 Temperature range	25℃ ±5℃
2-2	湿度 Humidity range	65%±10%

3. 机械特性 Mechanical Specification

No.	Item	Specification										
3-1	尺寸 Size	64X33X72										
3-2	重量 Weight	401.5g± 3g										
3-3	齿轮类型 Gear type	钢 Steel										
3-4	机构极限角度 Limit angle	200°										
3-5	轴承 Bearing	滚珠轴承 Ball bearings										
3-6	出力轴 Horn gear spline	15T										
3-7	外壳 Case	Aluminum										
3-8	舵机线 Connector wire	①50±1CM(黑红+黑红白)										
3-9	引脚定义 Pin Definition	<table border="1"> <tbody> <tr> <td>1</td> <td>Signal</td> </tr> <tr> <td>2</td> <td>VCC(5V)</td> </tr> <tr> <td>3</td> <td>GND</td> </tr> <tr> <td>4</td> <td>24-</td> </tr> <tr> <td>5</td> <td>24+</td> </tr> </tbody> </table> 	1	Signal	2	VCC(5V)	3	GND	4	24-	5	24+
1	Signal											
2	VCC(5V)											
3	GND											
4	24-											
5	24+											
3-10	马达 Motor	Brushless Motor										

4. 电气特性 Electrical Specification (Function of the Performance)

No.	工作电压范围 Working Voltage Range	10V-16V	
4-1	典型工作电压 Operating Voltage	12V	14.8V
4-2	静态电流 Idle current(at stopped)	45mA	45mA
4-3	空载速度 No load speed(+/- 10%Tolerance)	0.25sec/60° (40RPM)	0.204sec/60° (49RPM)
4-4	空载电流 Runnig current(at no load)	400mA	480mA
4-5	堵转扭矩 Peak stall torque	190kg. cm	220kg. cm
		2643.06oz. in	3060.39oz. in
4-6	堵转电流 Stall current	10.2A	12.3A
4-7	额定负载 Rated Torgue()	63kg. cm	73kg. cm
4-8	额定电流 Rated Current	3400mA	4100mA
4-9	Kt常数	18.62kg. cm/A	

产品规格书

Specification of Product

V1.0 Page 2/3

产品名称: 12V 190kg. cm数码180度磁编码全铝壳钢齿轮无刷舵机

产品型号 Model No. FT-150BL-C002

5. 控制特性 Control Specification:

No.	Item	Specification
5-1	控制信号 Command signal	Pulse width modification
5-2	控制系统类型 Control System Type	Digital comparator
5-3	脉冲宽度范围 Pulse width range	600→2400 μsec
5-4	停止位置 Stop position	1500 μsec
5-5	旋转角度 Running degree	180±2° (at 600→2400 μsec)
5-6	死区宽度 Dead band width	≤4 μsec
5-7	旋转方向 Rotating direction	顺时针 clockwise (在600→2400 μsec)

6. 外形图 The Drawings

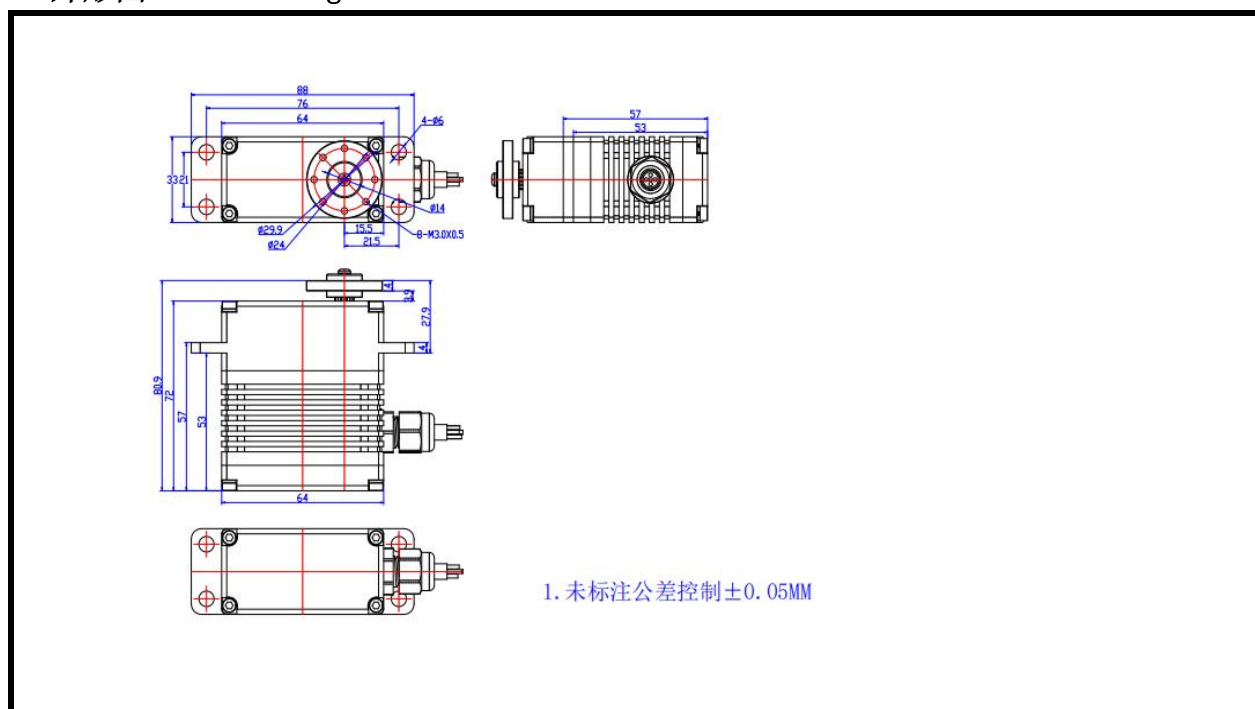

7. 配件 Accessories

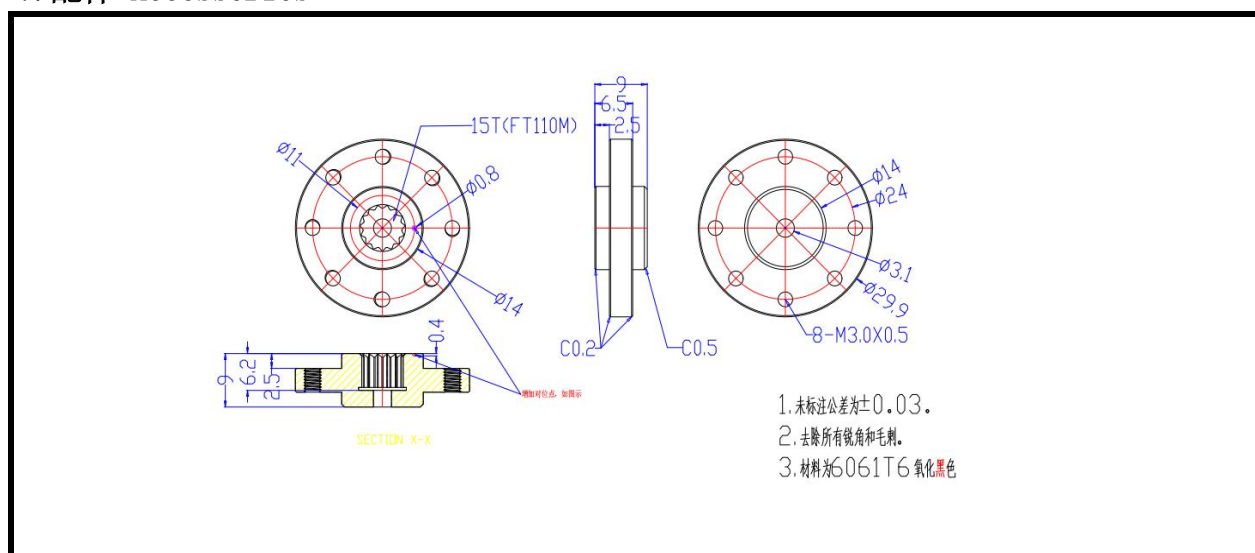

产品规格书

Specification of Product

V1.0 Page 3/3

产品名称: 12V 190kg. cm数码180度磁编码全铝壳钢齿轮无刷舵机

产品型号 Model No. FT-150BL-C002

8. 运动特性图 Performance

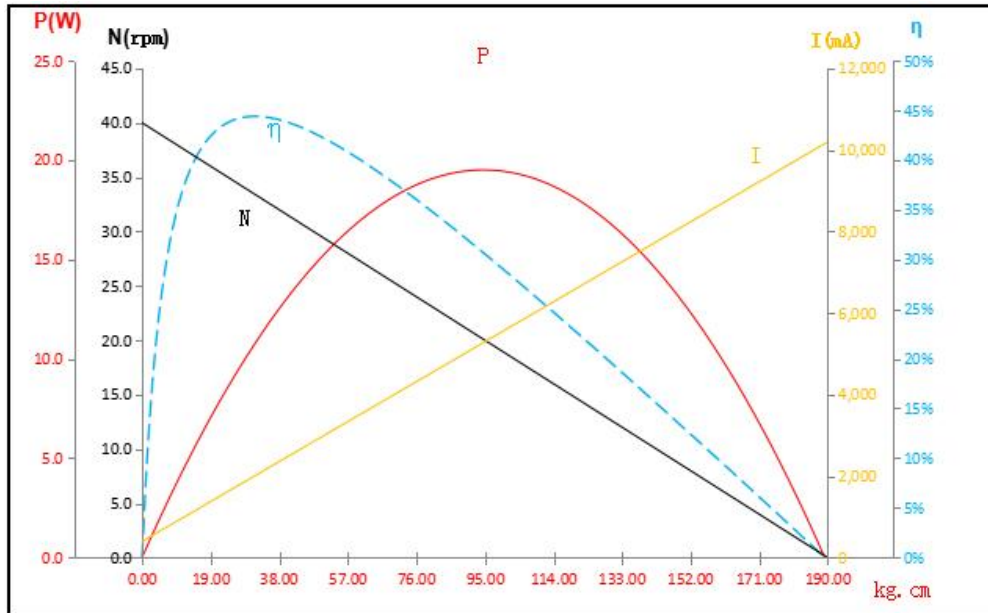

9. 包装出货简图 The Packaging Detail

